

Remote Monitor System – Wire-line ACM4314 Series

The Remote Monitor System, featuring wire-line audio and control, is designed for users to simultaneously monitor two channels selected from up to 20 audio circuits at a dispatch facility. A central audio matrix switch unit (CAMS) at the central site routes the individually selected audio channel to each remote monitor speaker. The desired audio channel is selected by up/down switches on the faceplate of the RMU.

Remote Monitor Unit

The remote monitor unit contains two speakers with volume control, mute switch and LED status indicator for each. An up/down channel selector for each speaker allows the operator to select the desired channels to monitor. A two-digit LCD display indicates the channel number selected for each speaker. Each channel has a separate controller and audio amplifier.

The RMU is packaged for desktop use. It is housed in a black, sloped-front plastic enclosure with an aluminum face plate. It is the size of an average key telephone unit. There is room on the face of the unit to place a card that lists the name of each channel to associate it with the displayed channel number.



Figure 1. ACM 4314 RMU

Monitor units can be placed anywhere within the site. All that is required are two 4 pair cables CAT-5 or Telco-type SP – terminated with RJ-45 connectors. The cables are wired straight through, pairs 1 and 2 are not inverted from end to end. The maximum cable length between the CAMS and each RMU is normally 150 feet. The RMU is supplied with two 10 foot RJ-45 jumper cables to connect the unit to a wall jack. The RMU is powered by an internal Gel-cell battery, which is charged by an external power supply. The Gel-cell battery life is typically 4 to 5 years.

Central Audio Matrix Switch

The central audio matrix switch unit is connected to the recorder output or similar 600 Ohm balanced audio interface at the central electronics bank (CEB) with a 25 pair Telco-type cable connector. The 1 RU enclosure is 19" rack mounted near the CEB.

A 32 X 16 port audio matrix, wired for 20 input channels and 16 output channels is controlled by a micro-controller. All audio ports are transformer isolated, configured for +1dbm to -20dbm range input. Each RMU channel selector can individually switch the matrix output via the micro-controller. Each unit has a clock and data line connected to the CAMS for the individual control.

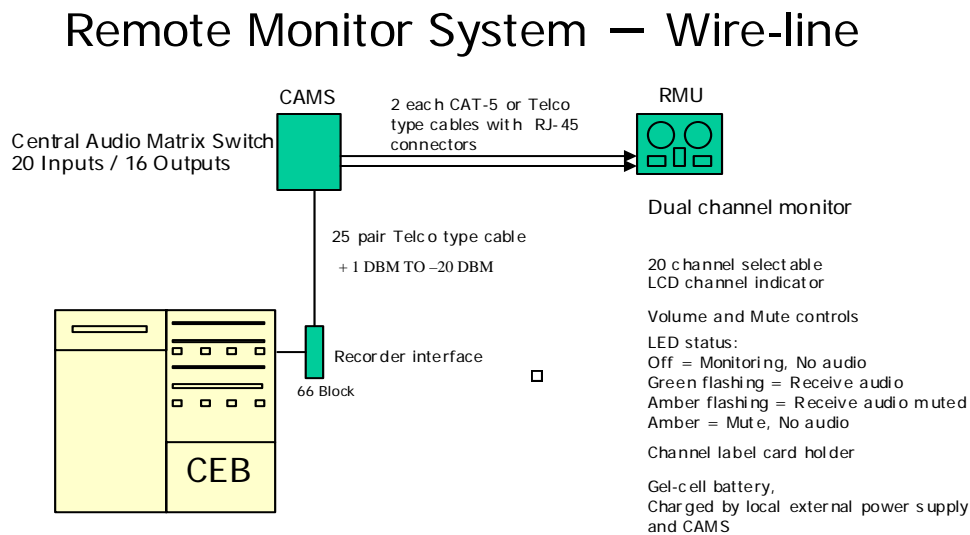

Figure 2. Typical ACM 4300 Configuration

RJ-45 Cable Connections

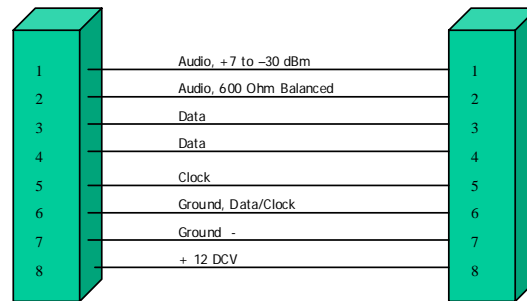

Figure 3. CAMS to RMU RJ-45 cable connections

There are 16 RJ-45 connectors on the back panel of the CAMS for cabling to the remote monitors, two per RMU.

An external power unit supplies 12 VDC to the CAMS charging it's internal battery. The central unit supplies charging voltage to the RMU battery. An external power supply is included with each RMU.

The AWQ8072 (ACM4300 Series) Remote Monitor System, consists of:

ACM4314	CAMS	Central Audio Matrix Switch
ACM4315	RMU	Remote Monitor Unit, 2 Channel

Accessories included:

- 1 each Power Supply, CAMS (AW4314-1)
- 2 each RJ-45 M-M Jumper Cable, 10 feet, per RMU (AW4315-2)
- 1 each Power Supply, RMU (AW4315-1)
- 1 each Channel labeling software (CD) and paper stock

Replacement Parts

Gel - cell Battery, CAMS (AW4314-2) 12 V 2.4 AH SLA

CAMS External Power Supply (UL Listed) (AW4314-3)

RMU External Power Supply, RMU (AW4315-1)

Housing, includes back plate (AW4315-3)

Faceplate (AWP4315-4)

Channel Card (AW4315-5) Plate kit includes clear cover, back card, 2 thumb screws, labels and a CD with label writing software.

Gel-cell Battery, RMU (AWP4315-6) 12 V 1.4 AH SLA

Speaker Amp Kit (AW4315-7) Includes Speaker, circuit board, knobs ,switch and mounting hardware.

Controller Display and Switch Kit (AW4315-8) Includes circuit board and mounting hardware.

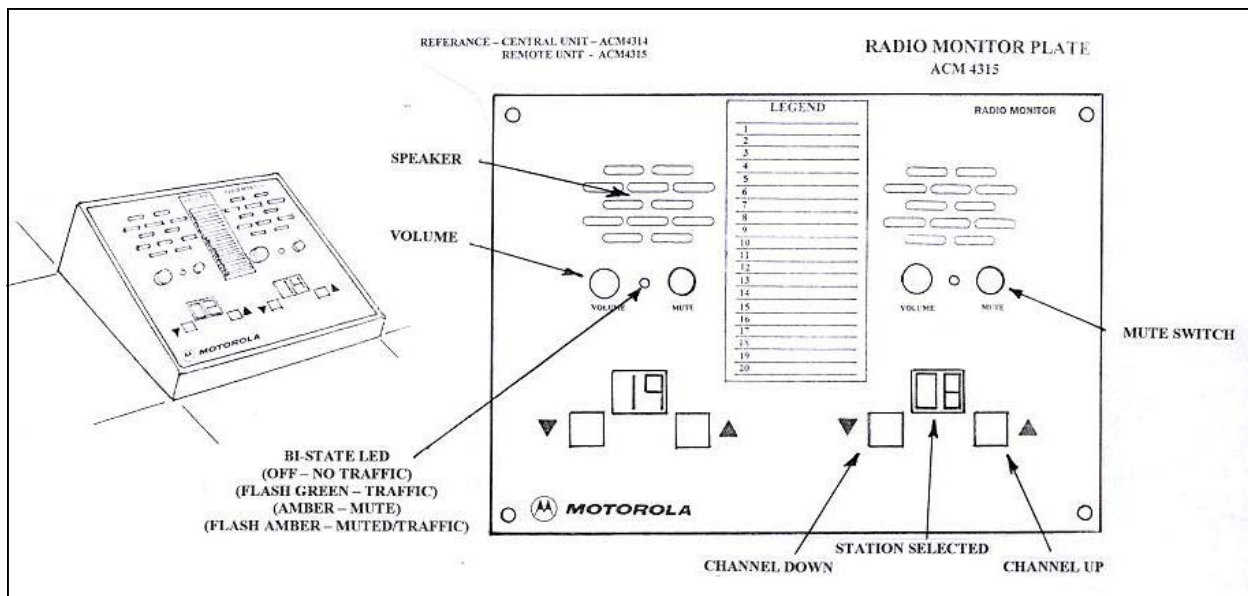

Manufactured for **Motorola**
 by

American Wireless Inc.

1780 East McFadden Ave., STE 112 • Santa Ana, CA 92705

Phone: 888-289-1555 • Fax: 714-542-0313

Email: info@awicom.com Web site: <http://www.awicom.com>